



King Abdullah University of  
Science and Technology



# Advancing the Development of Solar Building Technology for the Future

Presented by: Dr. Bin-Juine Huang

Department of Mechanical Engineering  
National Taiwan University, Taipei, Taiwan

# Outline of presentation



- I. Importance of solar building technology**
- II. NTU's efforts in developing solar building technology**
- III. Supported Researches by GRP CID Award**
- IV. How to work with KAUST**

# • Where is energy consumed ?



- About 80% of energy in the world is consumed within various buildings (homes, factories, supermarkets, railway stations, offices, gymnasiums, .....etc)
  - Air conditioning and heating contribute to about 30-50% of the total building energy consumption
  - Indoor- or outdoor- lighting contribute to about 15-25%.
- Reducing energy consumption in cooling/heating systems and lighting can thus contribute a great deal to reducing global warming and extending the petroleum economy.
- Water supply is also an equally important issue for the buildings.



# • Importance of solar building technology



- **Solar building technology** deals with solar energy collection and power generation, energy storage and utilization, water supply, lighting, and architecture.  
[structure/function/beauty +energy/material recycle +solar energy utilization]
- **Solar building technology** involves the utilization of solar energy in cooling, heating, lighting, and water supply systems for the buildings to reduce global warming and extend the petroleum economy.
  - **However, several problems need to be solved :**
    1. **need innovative solar technology for building applications**
      - Efficient solar cooling/heating, desalination, and lighting devices, etc.
    2. **need innovative design to solve installation problem of solar equipments in buildings**
      - Building-integrated solar equipments, etc.



# Where to install solar collectors ?

## Taiwan



## China (world largest solar market)





## **II. NTU's efforts in developing solar building technology**



# • Major research topics



- Heat pump
- Solar cooling technology
- Building-integrated solar collector
- LED (light-emitting diode) solid-state lighting

# New solar water heater (Solar-assisted heat pump)

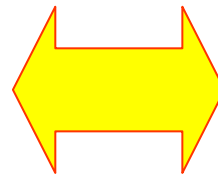

# Waste heat recovery by heat pump



- Heat pumps installed in parking lot

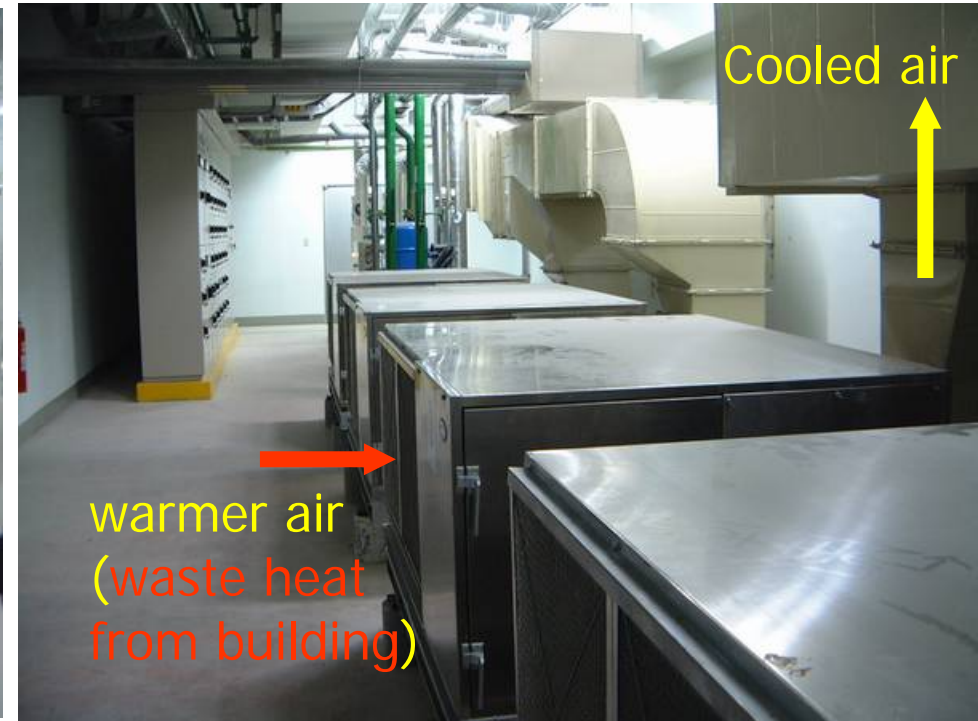

- fast market development: > 50M USD/yr (2007) from zero in 2004 (Taiwan)



# Huge energy is stored in building structure

- For a concrete wall with dimension 3.5m high x 20m long x 20cm thick:  
(about a standard **5mx5m** living room)
  - **Total mass: 29.4 ton**
  - **Energy density: 26 MJ/°C**
- Daily hot water demand per person: 6.3 MJ/day
- Taking 1°C of heat from the concrete wall of a living room can supply enough hot water for 4 persons per day !

**Building is a huge energy storage device !**



# Building-integrated solar collectors

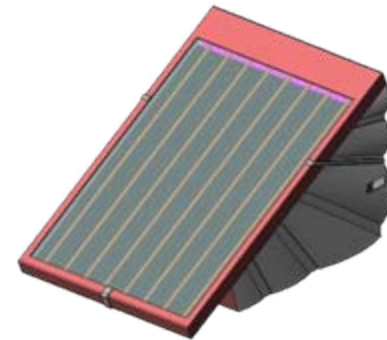

# Solar cooling technology (since 1978)

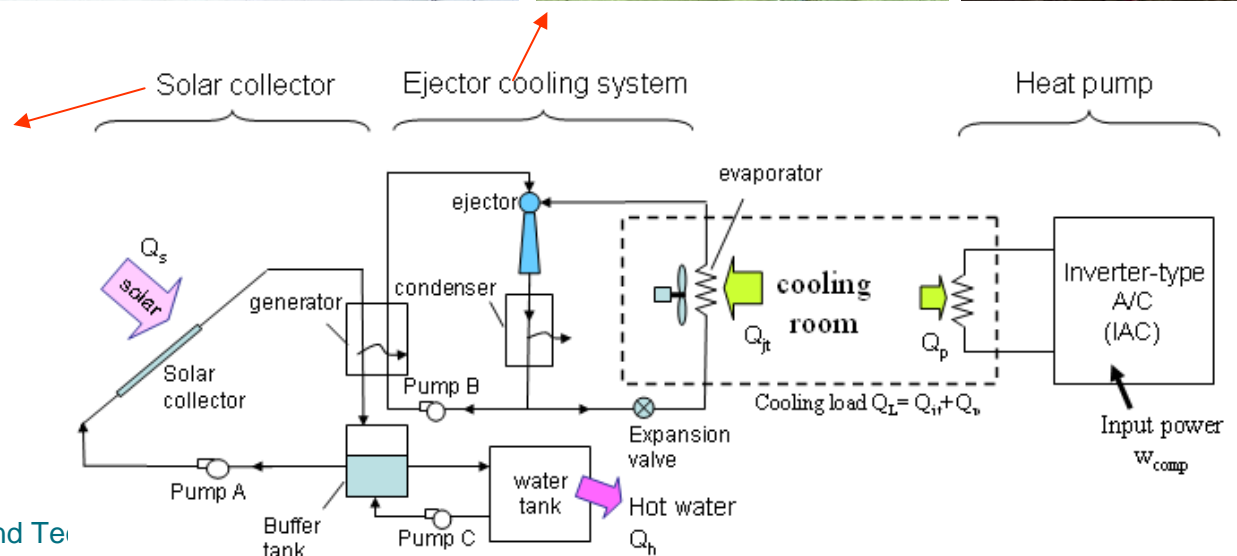
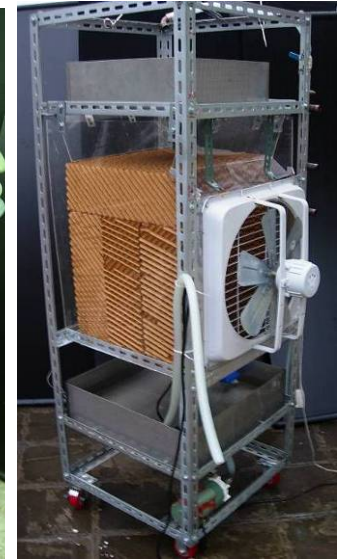



# Solar-powered lighting technology (2003- )

- Involving two key technologies:
  - Solar photovoltaic (PV) power generation
  - LED lighting

Taiwan is one of the world major suppliers of PV and LED  
PV -- the fifth largest  
LED – the second largest



# LED (light-emitting diode) solid-state lighting – a next-generation lighting



**72W LED / NTU campus lamp**

15-20% world energy is consumed in lighting.



# NTU Campus 200m LED road test (150W×6)- the first in the world (2006)

Road width: 9.5m

Lamp height: 5.2m

Pole distance: 30m-30m-36m-33m-36m

Replacing 400W mercury light

Net light output per lamp: 8,000Lm@150W



145Lux

Since 2006.2



# Solar-powered LED landscape lighting (power consumption: 60W)





# LED landscape lighting "Flying over rainbow" (total power consumption < 100W)





# **III. Supported Researches by GRP CID Award**



# • Research topics of GRP CID Award



- **Plan A: Solar-assisted cooling/heating and desalination**
- **Plan B: Solar-powered LED lighting for desert area**

The applications in Saudi Arabia is in an entirely different environment (hot and dry), thus the research will face a big challenge in modifying all the related technologies.

# Research sub-plans



## **Plan A. Solar-assisted cooling/heating and desalination for building (SACH)**

A-1 Ejector design study

A-2 SACH system technology for application in dessert area

A-3 Solar-assisted membrane distillation (SAMD) system technology

A-4 Solar collector development for SACH and SAMD

## **Plan B. Solar-powered LED lighting (sLED)**

B-1 Solar-powered LED lighting system technology for dessert area

B-2 Super-capacitor storage for solar-powered LED lighting system

B-3 Dye-sensitized solar cell (DSSC) development for tropical weather

B-4 Self-clean glazing material development.

# Research Team



## **11 professors involved**

### **Principal Investigator (PI) :**

Bin-Juine Huang<sup>+</sup>, Professor, Dept. of Mechanical Engineering, National Taiwan University, Taipei, Taiwan

### **Co-Principal Investigator (co-PI) :**

Nae-Lih Wu, Professor, Dept. of Chemical Engineering, National Taiwan University, Taipei, Taiwan

### **Other Key Participants :**

- P.H. Chen (Professor)<sup>+</sup> and S.L.Chen (Professor) <sup>+</sup>, Dept. of Mechanical Engineering, National Taiwan University
- J. J. Lin (Professor), Institute of Polymer Science and Engineering, National Taiwan University
- K.C. Ho (Professor) , D. J. Lee (Professor), D.M. Wang (Professor), Dept. of Chemical Engineering, National Taiwan University
- V. Petrenko<sup>+</sup>, Professor, Odessa State Academy of Refrigeration, Odessa, Ukraine.
- J.M. Chang<sup>+</sup> and C.W.Lu<sup>+</sup>, Associate Professor, Dept. of Mechanical Engineering, National Chin-Yi University of Technology

**30~40 PhD or MS research students**

**3 post-doctors or research engineers**

**3 engineering staffs**

**2 administrative faculties**

# • Solar cooling/heating technology (A-1,A-2)



- Solar heating system produces too much heat in summer
- The research tries to convert the excess heat into cooling in summer to reduce the energy consumption of air conditioners.

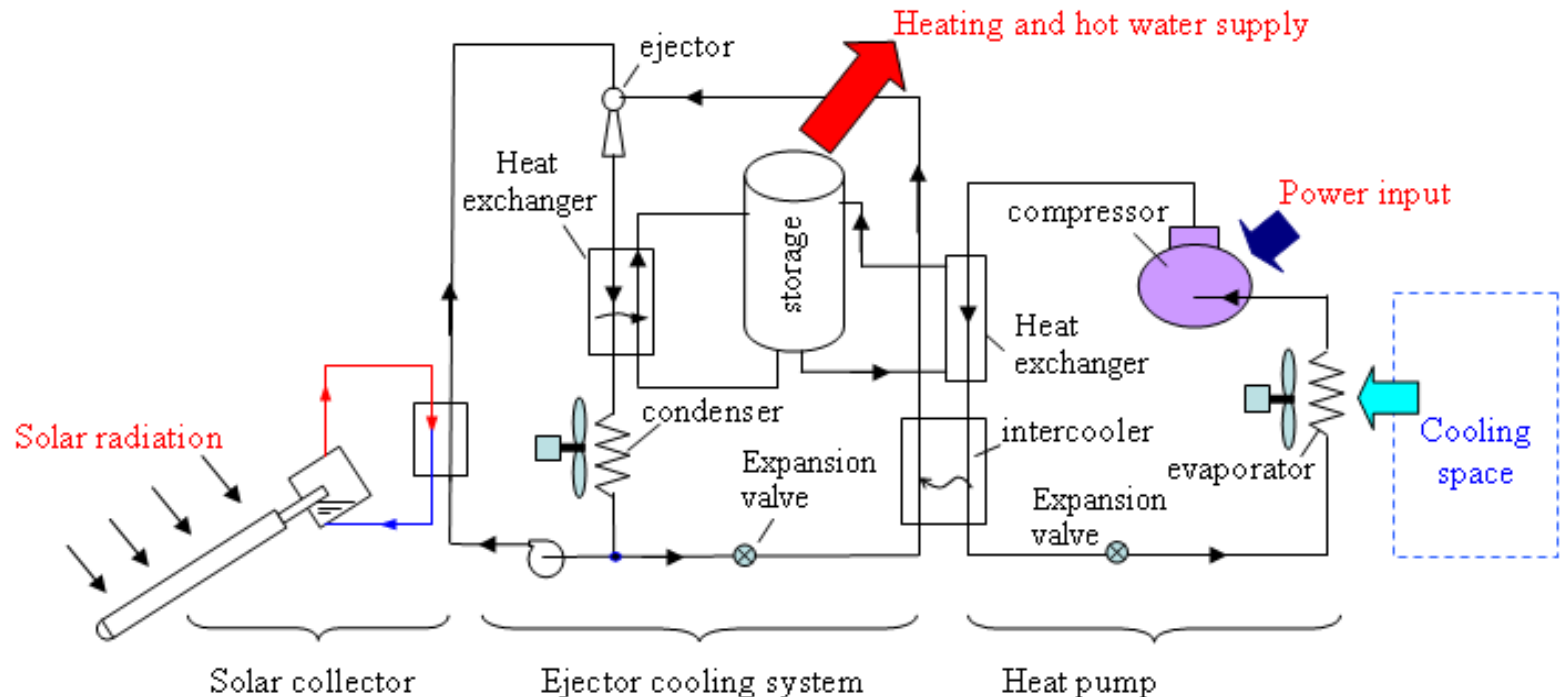



# Solar desalination for building (A-3)

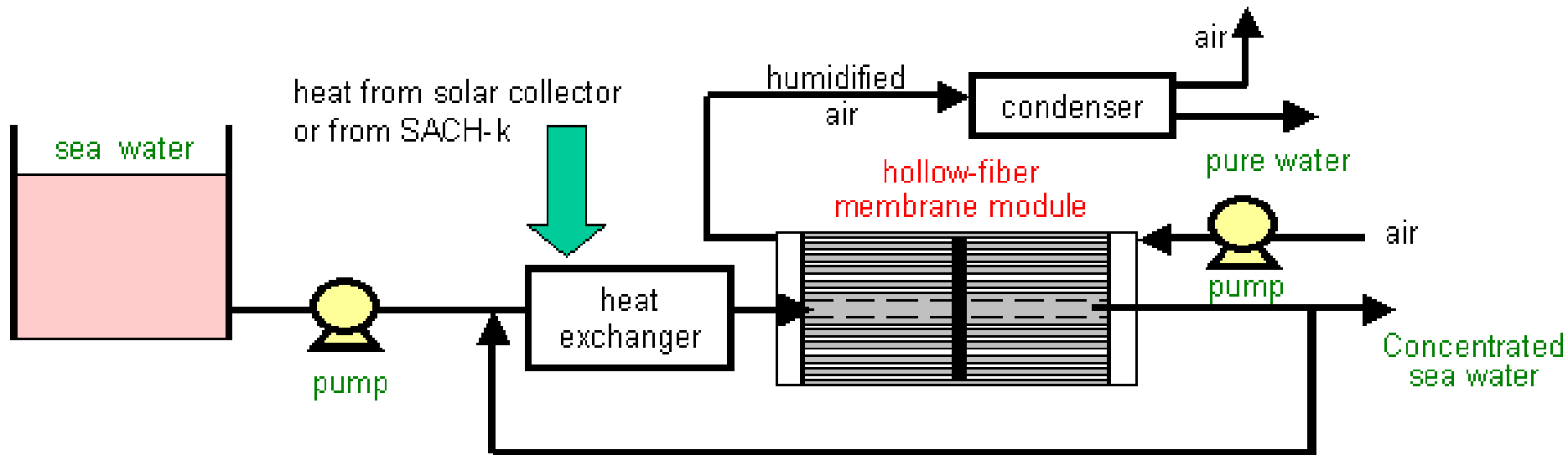

# Solar collector for cooling and desalination (A-4)



- New vacuum tube collector

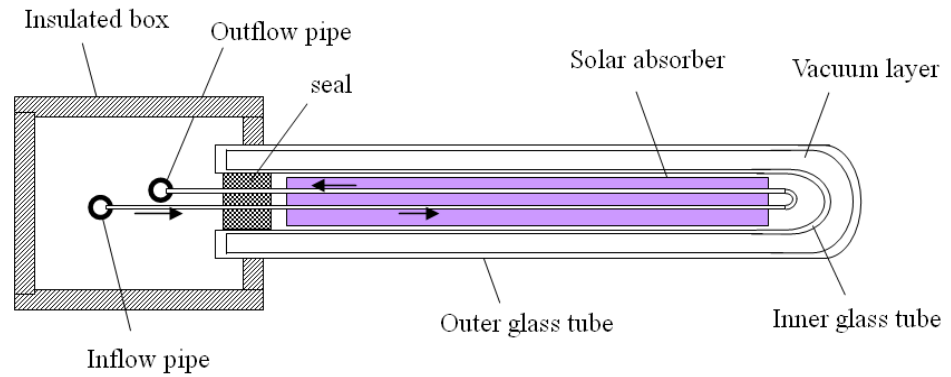

- Building-integrated collector



Low profile wall

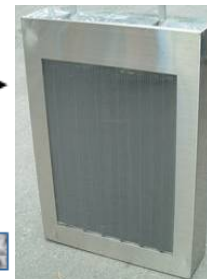
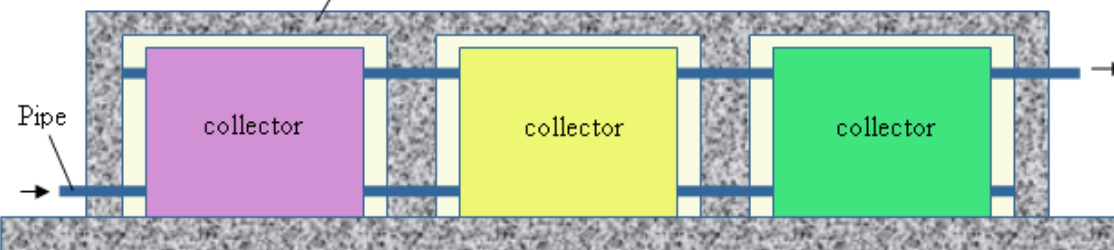



# • Solar-powered LED lighting for desert area (B)



## 1. Indoor LED lighting technology for desert application

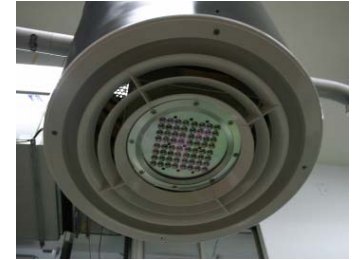

## 2. Solar-powered LED lighting system

### • Intelligent control system

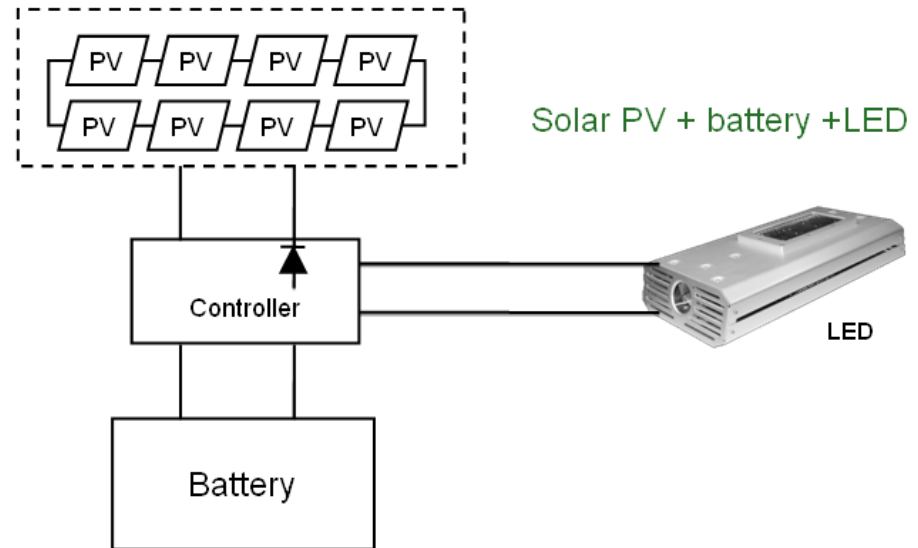



# 1. Advanced LED lighting technology (B-1)



**mini compressor  
(1.2 kg)**

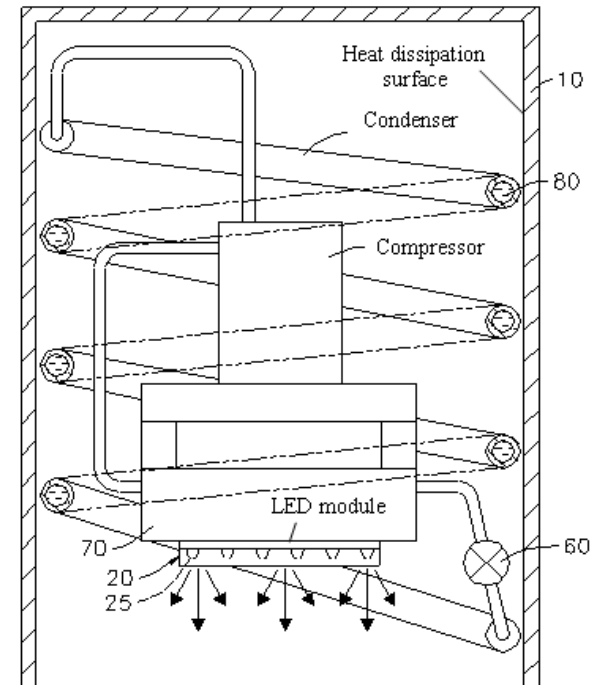
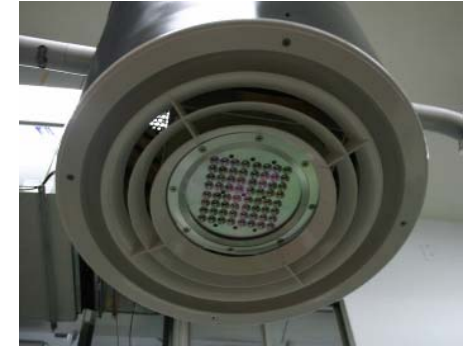

## 2. Solar-powered LED lighting for highway (B-1, B-2)

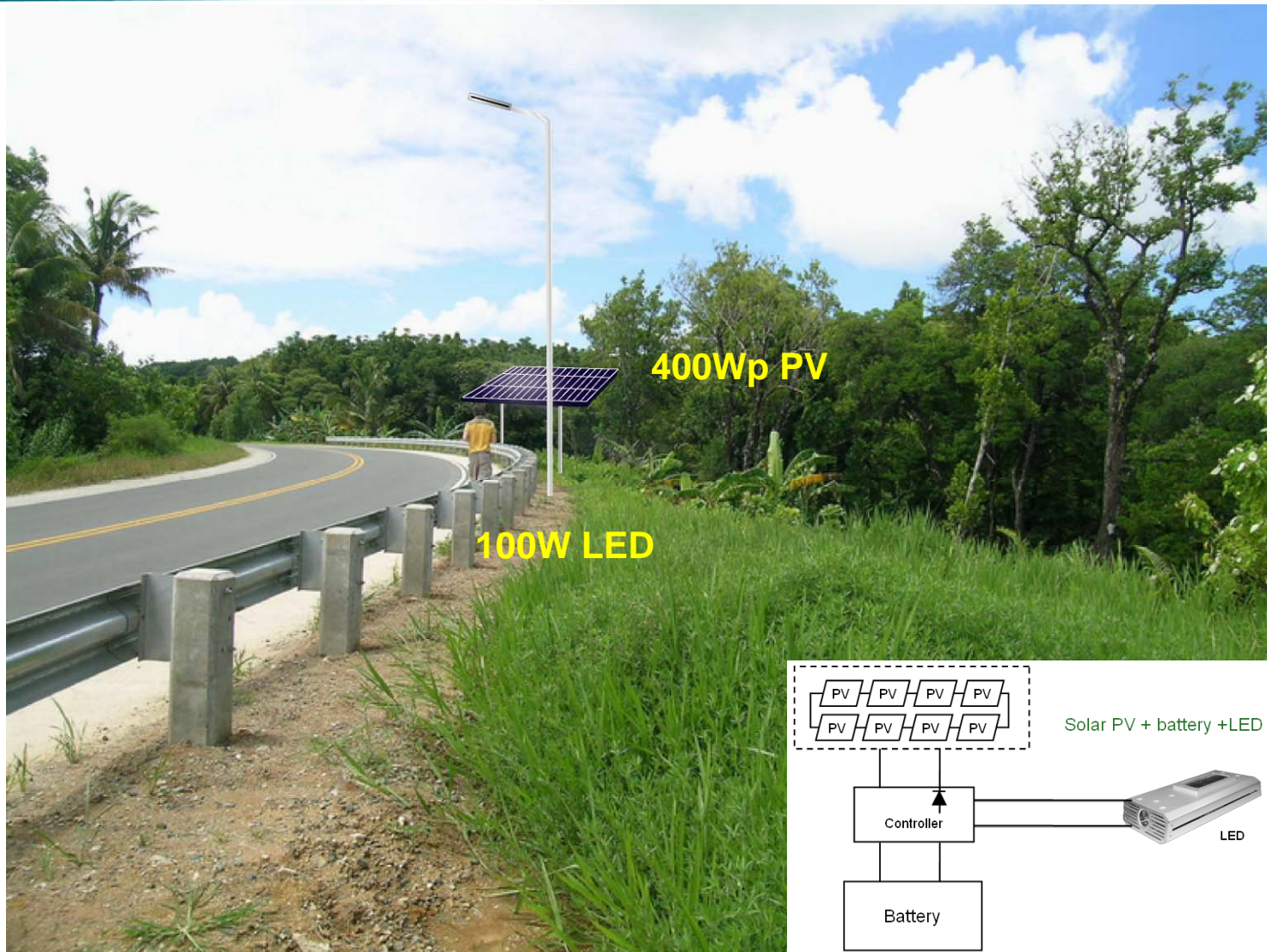



# Solar-powered LED lighting field test in NTU campus (2006- )



- The payback time of solar-powered LED lighting for highway is around 3 years.



# IV. How to work with KAUST

# • Opportunities for field work in KAUST



- Demonstration and field test of indoor LED lighting in dessert area (KAUST) – Year 2
- Field test of solar-powered LED lighting for highway (~10km) in Saudi Arabia – Year 2 & 3
- Demonstration of solar-assisted cooling system to reduce energy consumption of air conditioner in KAUST – Year 3
- NTU will work together with the teams from KAUST and Taiwan industries for the demonstration and field test in Saudi Arabia.

# • Operation of NTU's CID Project



- Technology research and development in NTU
  - Joining and expanding the existing R&D projects in NTU to meet the application conditions in Saudi Arabia
  - Initiating a new concept of design and carry out the R&D in NTU and transfer to KAUST
  - Inviting industries to join the research to incubate or spawn a new industry in Taiwan and Saudi Arabia
- Training and education for KAUST
  - Accepting researchers or graduate students from KAUST to join the research projects in NTU for training and future technology transfer
  - Student exchange program between KAUST and NTU
    - Engineering design training (design projects)
    - R&D with industry

# • Training and education



## Engineering design projects for students (3-6 months)

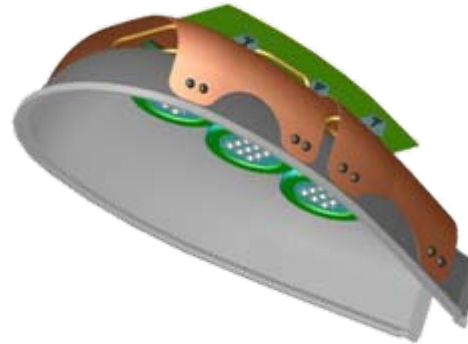
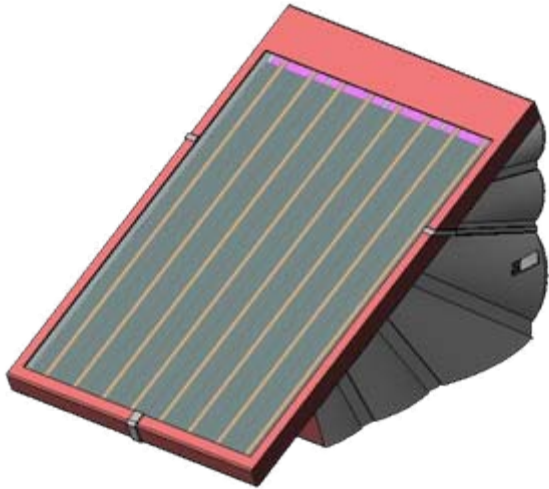

LED light



Solar collector



solar refrigerator



# Student benefits

- By joining the fundamental research of the core technology, students will *learn how to solve the product development problem using the scientific knowledge and innovation*, and build the prototype for verification.
- By joining the technology transfer or licensing to industry for product development, students can *learn the management of technology transfer*.
- By joining the industry funding R&D projects, students will *learn the product development from working together with industry*. They also *learn the process of knowledge implementation in product development* and may finally work for the company after their graduation.
- For incubation of new industry, students have opportunity to work for the new company to *create their new career*.

# • Industrial partnership



- KongLin Group for solar architecture, building-integrated collector
- ATD Inc for high-power LED lighting
- L&C Lighting Co for full-color LED lighting, active-cooling LED
- Suntek Solar Ltd for SACH, solar collector, heat pump
- Attes Ltd for SACH and vacuum tube collector
- Foxconn Tech Co for mass production and business operation (Industrial operation)
- German Trade Office in Taipei for technical support of solar architecture
  - Chief adviser of advisory committee of NTU's CID project: Dr. Jason Pei, President of Foxconn Tech Co (the largest manufacturer in China and Taiwan)
  - NTU will bring Taiwan industry together to Saudi Arabia through KAUST for local energy industry development.

# • Preliminary plan for Solar Energy Research Center of KAUST



- Expanding the GRP CID Award's task force to include solar architecture and renewable energy power generation technology with governmental and industrial supports

## Solar Energy Research Center

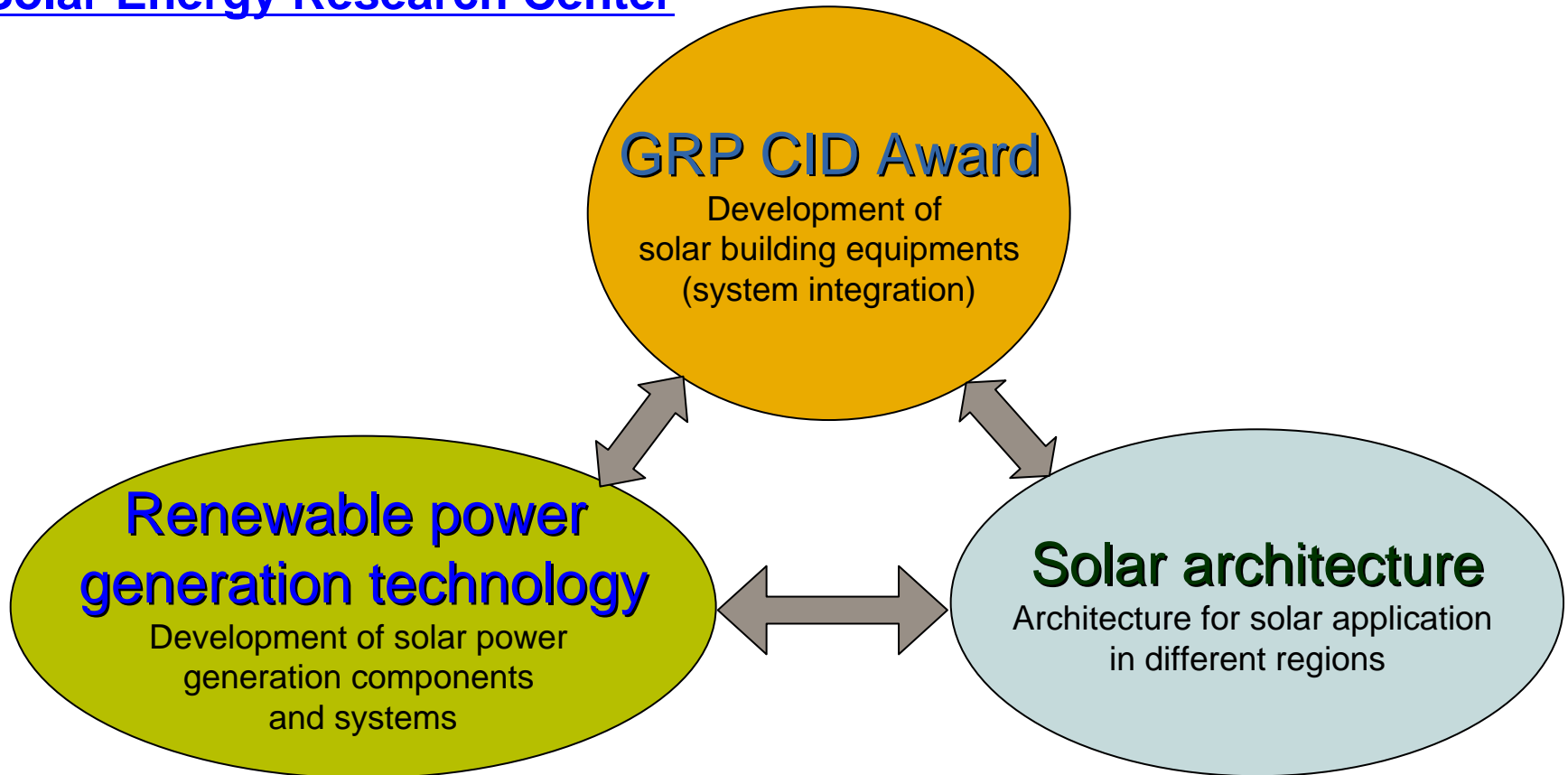



King Abdullah University of  
Science and Technology



# Thank you